

More information:  
[www.blug.es/eng/productos/](http://www.blug.es/eng/productos/)

**BLUG**<sup>®</sup>  
 Credeblug, s.l.

**MACHINE TYPE**  
**UNDERWATER GRAB**  
**WORKING SYSTEM**  
**ELECTRO-HYDRAULIC**  
**MATERIAL TO BE HANDLED**

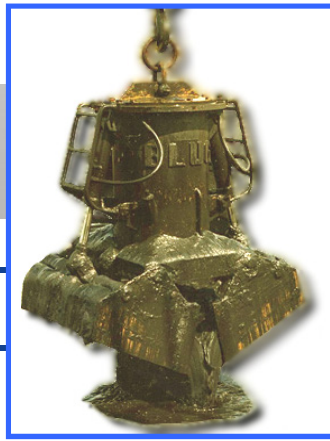

**REFERENCE**  
**C2A-2,8**

p. 15



**MAX. MATERIAL DENSITY**  
**2,8 T/M<sup>3</sup>**  
**APPLICATION**  
**STEEL WORKS**



**C2AE-2,8**



**C2AP-1,8**



**PEA-1,1**

**SUMERGED MATERIALS, SLIMES, SANDS, STONES...**

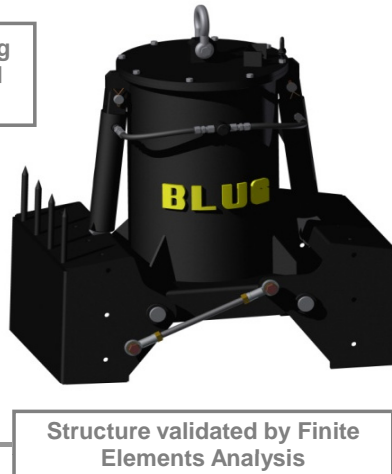
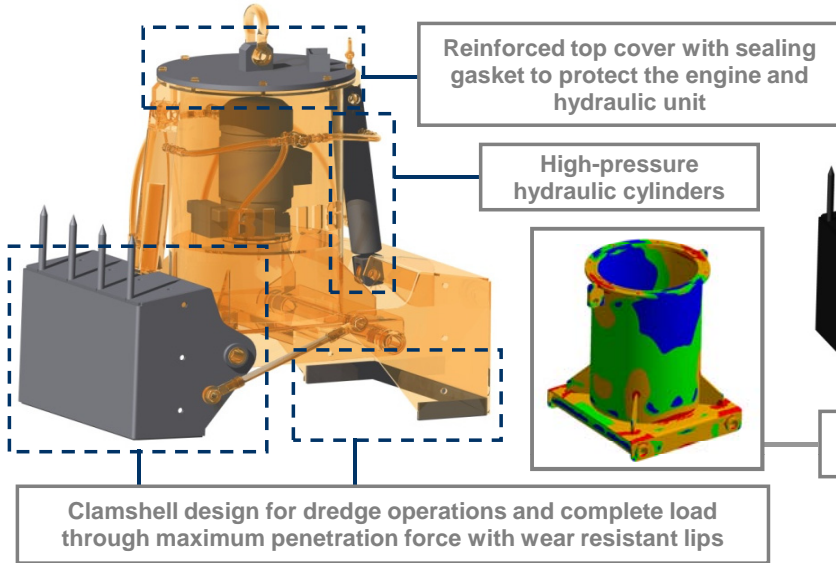

**Equipment needed**

- Hook(s) or lifting chain(s).
- Electric connection for hydraulic unit.

**Technical information**

- Robust structure in S355 J2G3 rolled steel.
- Leak-proof pressurized oil deposit.
- Reduced height, multi-stable, can work at any angle ( $\pm 60^\circ$ ).
- Anticorrosive and anti-oxidant surface treatment with EPOXI-TAR.
- Draining holes and/or cleaning gombs included.
- Design & fabrication according to standard FEM 1001/98 section I.
- CE conformity.

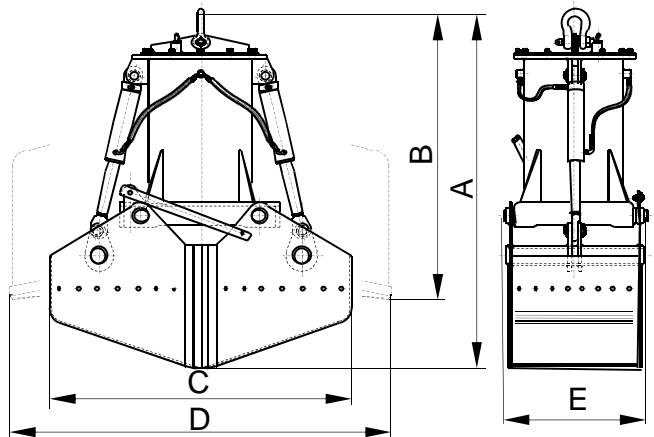

Reference	Capacity	Engine	Intensity 400 V	Working pressure	Closing time	Opening time	Crane SWL	Weight kg	Dimensions mm				
									A	B	C	D	E
C2A-100-2,8	0,1	3	6,7	100	5	3	1	390	1265	1210	835	1060	605
C2A-150-2,8	0,15	3	6,7	100	5	3	1	420	1350	1230	835	1215	605
C2A-250-2,8	0,25	4	8,95	120	6	4	1,25	460	1525	1260	1165	1550	605
C2A-300-2,8	0,3	4	8,95	120	6	4	1,6	480	1550	1280	1190	1575	605
C2A-500-2,8	0,5	4	8,95	120	9	5	2,5	650	1700	1485	1310	1770	770
C2A-750-2,8	0,75	5,5	11,5	130	9	5	3,2	750	1840	1525	1580	2035	770
C2A-1000-2,8	1	7,5	15,5	160	9	5	4	860	2060	1580	1890	2450	770
C2A-1250-2,8	1,25	11	22	160	10	5	5	1400	2330	1970	1980	2470	940
C2A-1500-2,8	1,5	11	22	170	10	5	6,3	1520	2360	1975	2240	2525	940
C2A-1750-2,8	1,75	11	22	180	10	5	8	1790	2380	1980	2270	2585	1200
C2A-2000-2,8	2	11	22	190	10	5	8	1850	2400	1980	2300	2610	1200

SUBJET TO CHANGE WITHOUT NOTICE.

You can request any model's offer visiting our web site [www.blug.es](http://www.blug.es) or sending an email to [comercial@blug.es](mailto:comercial@blug.es)