

More information:

www.blug.es/eng/productos/

BLUG[®]

Credeblug, s.l.

MACHINE TYPE

UNDERWATER GRAB

WORKING SYSTEM

ELECTRO-HYDRAULIC

MATERIAL TO BE HANDLED

SUMMERGED MATERIALS, SANDS... SPECIFIC FOR WASTE WATER TREATMENT PLANTS (W.W.T.P.)

REFERENCE

C2AE



p. 16

RELATED PRODUCTS



C2A-2,8



C2AP-1,8



PEA-1,1



MAX. MATERIAL DENSITY

2,2 T/M³

APPLICATION

W.W.T.P.

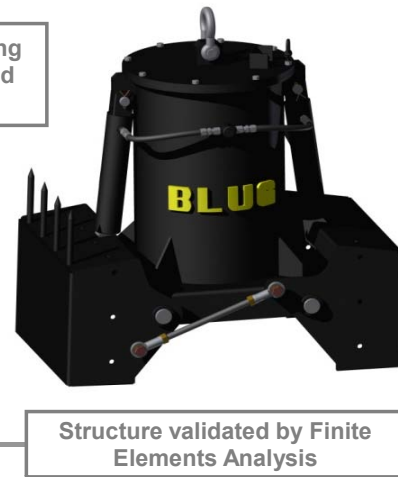
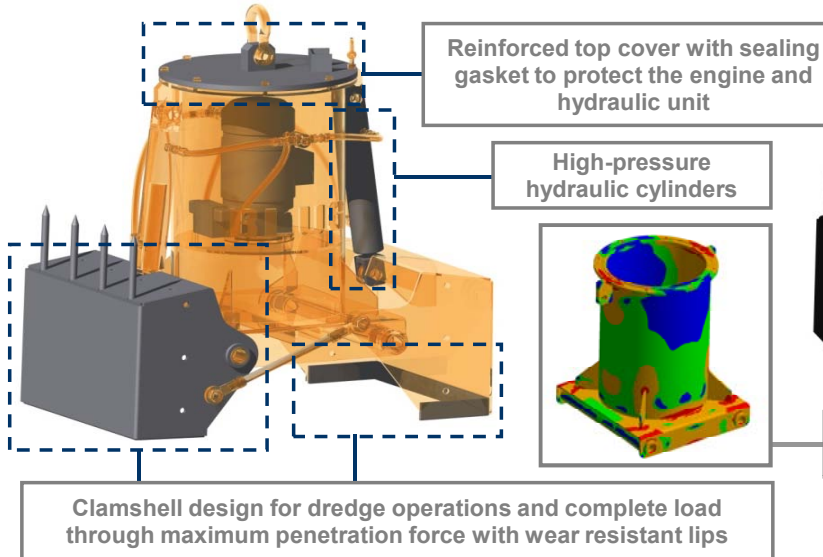

Equipment needed

- Hook(s) or lifting chain(s).
- Electric connection for hydraulic unit.

Technical information

- Robust structure in S355 J2G3 rolled steel.
- Leak-proof pressurized oil deposit.
- Reduced height, multi-stable, can work at any angle ($\pm 60^\circ$).
- Anticorrosive and anti-oxidant surface treatment with EPOXI-TAR.
- Draining holes and/or cleaning gombs included.
- Design & fabrication according to standard FEM 1001/98 section I.
- CE conformity.

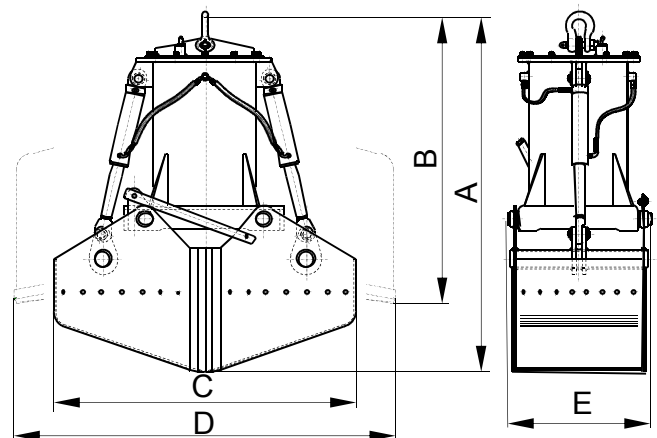

Reference	Capacity	Engine	Intensity 400 V	Working pressure	Closing time	Opening time	Crane SWL	Weight kg	Dimensions mm				
									A	B	C	D	E
C2AE-50	0,05	2,2	5,15	70	7,5	5,5	1	340	1150	1100	850	980	635
C2AE-100	0,1	2,2	5,15	70	7,5	5,5	1	370	1190	1100	950	1080	635
C2AE-150	0,15	2,2	5,15	70	7,5	5,5	1	380	1230	1100	995	1125	635
C2AE-250	0,25	2,2	5,15	70	7,5	5,5	1,25	460	1350	1100	1340	1420	635
C2AE-300	0,3	2,2	5,15	70	7,5	5,5	2	470	1385	1100	1375	1465	635
C2AE-500	0,5	3	6,7	95	7,5	5,5	2	560	1410	1100	1510	1500	885

SUBJET TO CHANGE WITHOUT NOTICE.

You can request any model's offer visiting our web site www.blug.es or sending an email to comercial@blug.es