

More information:  
[www.blug.es/eng/productos/](http://www.blug.es/eng/productos/)

**BLUG**<sup>®</sup>  
 Credeblug, s.l.



REFERENCE

**C2H-1,1**

p. 21

RELATED PRODUCTS



**C2-1,1**



**PEA-1,1**



**C4-1,1**

MACHINE TYPE  
**CLAMSHELL GRAB**

MAX. MATERIAL DENSITY

**1,1 T/M<sup>3</sup>**

WORKING SYSTEM

**ELECTRO-HYDRAULIC**  
 MATERIAL TO BE HANDLED

TYPE

**LOW HEIGHT**

**PILED AND BULK MATERIAL UP TO 1,1 t/m<sup>3</sup> DENSITY**

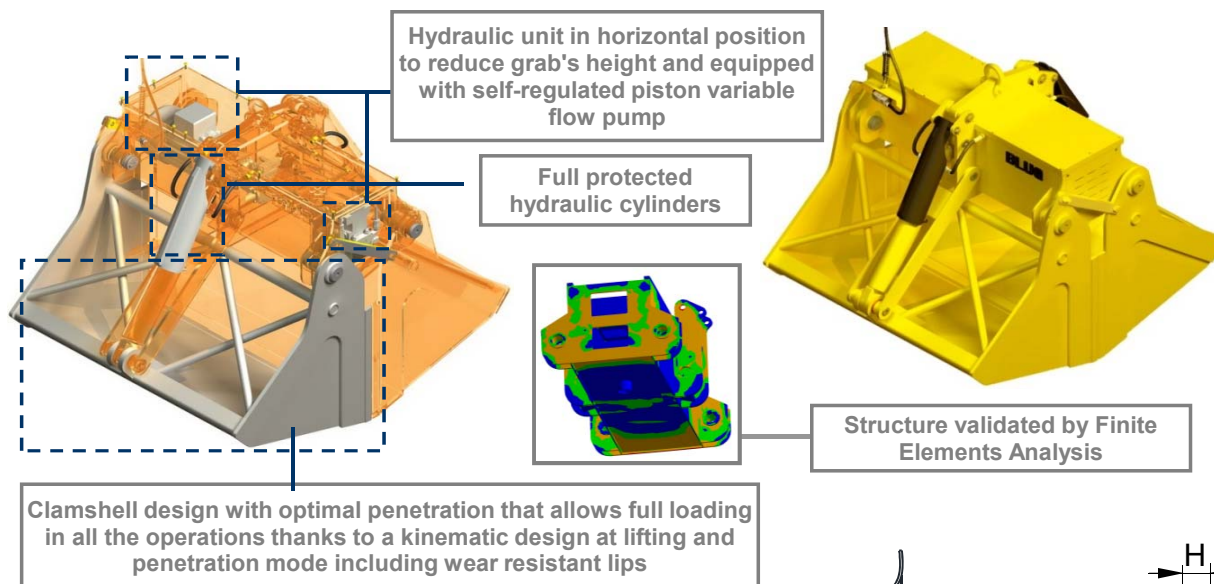

**Equipment needed**

- Hook(s) or lifting chain(s).
- Electric connection for hydraulic unit.

**Technical information**

- Robust structure in S355 J2G3 rolled steel.
- Oil tank tightly enclosed and protected from environment impurities.
- Reduced height, multi-stable, can work at any angle ( $\pm 60^\circ$ ).
- Design & fabrication according to standard FEM 1001/98 section I.
- CE conformity.

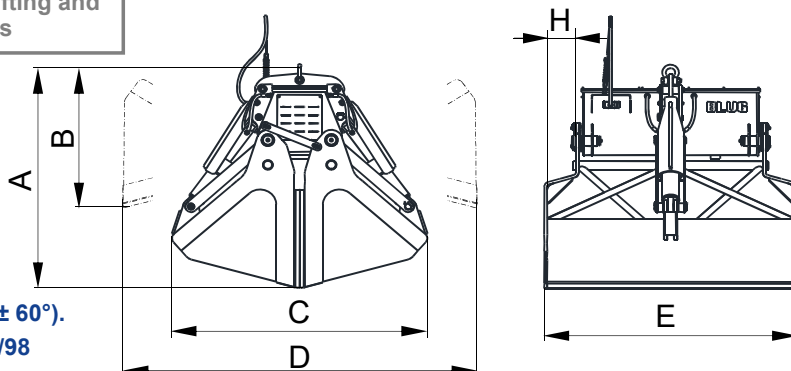

Reference	Capacity	Engine 40% ED	Intensity 400 V	Working pressure	Closing time	Opening time	Crane SWL	Weight	Dimensions					
									mm	A	B	C	D	E
C2H-1500-1,1	1,5	7,3	14,5	150	9,5	5	3,2	1490	1720	1130	1840	2540	1700	120
C2H-2000-1,1	2	10	20	200	9,5	5	4	1680	1825	1160	1970	2735	1950	245
C2H-3000-1,1	3	10	20	170	14	7	6	2625	2065	1500	2485	3220	1800	0
C2H-4000-1,1	4	14,5	28	220	14	7	8	2930	2190	1355	2695	3465	2100	150
C2H-5000-1,1	5	14,5	28	180	13	6	10	3400	2335	1430	2870	3725	2305	205
C2H-6000-1,1	6	20,5	39	220	13	6	12	3900	2465	1465	3060	3965	2305	205
C2H-7000-1,1	7	25,5	48,5	190	13	6	14	4730	2580	1540	3225	4125	2500	255
C2H-8000-1,1	8	25,5	48,5	220	13	6	16	5020	2630	1555	3295	4225	2700	355

SUBJECT TO CHANGE WITHOUT NOTICE.

You can request any model's offer visiting our web site [www.blug.es](http://www.blug.es) or sending an email to [comercial@blug.es](mailto:comercial@blug.es)