

More information:
www.blug.es/eng/productos/

BLUG[®]
 Credeblug, s.l.

MACHINE TYPE
CLAMSHELL GRAB
WORKING SYSTEM
HYDRAULIC
MATERIAL TO BE HANDLED

STONES, GRAVEL, SAND, MUDS, UNDERWATER WASTES IN DRAINAGE WORKINGS, PILED AND BULK MATERIAL UP TO 2,8 t/m³ DENSITY

REFERENCE
CNAH-2,8

p. 32

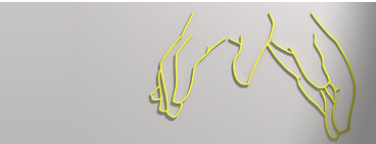

MAX. MATERIAL DENSITY
2,8 T/M³
CYLINDER QUANTITY
2



PNA-3



C2-2,8

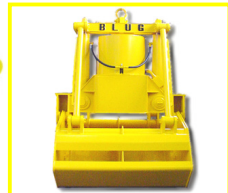

CV2-2,8

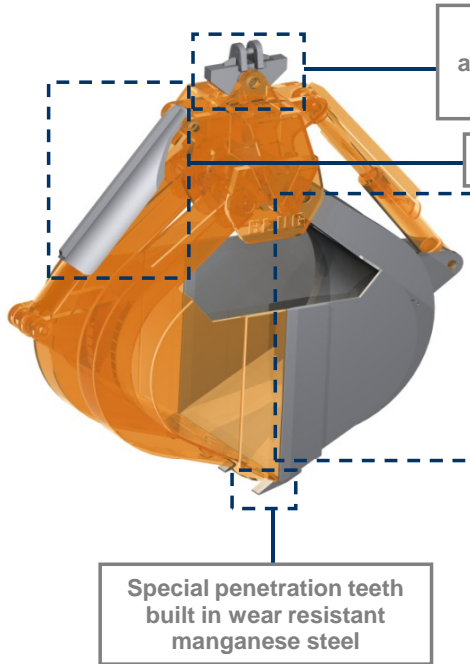

Adapted lifting rock-level for each application and forklift truck or mobile crane with optional rotation device

Full protected hydraulic cylinders

Clamshell design with optimal penetration that allows full loading in all the operations thanks to a kinematic design at lifting and penetration mode

Special penetration teeth built in wear resistant manganese steel

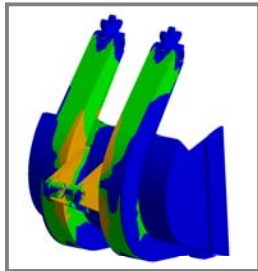
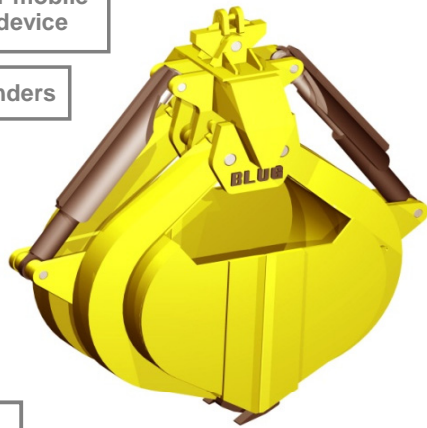

Structure validated by Finite Elements Analysis

Equipment needed

- Attachment from forklift truck / mobile crane.
- Hydraulic supply from external system.

Technical information

- Robust structure in S355 J2G3 rolled steel.
- Mechanical (120°) or hydraulic (360°) rotation device.
- Reduced height, multi-stable, can work at any angle (± 60°).
- Design & fabrication according to standard FEM 1001/98 section I.
- CE conformity.

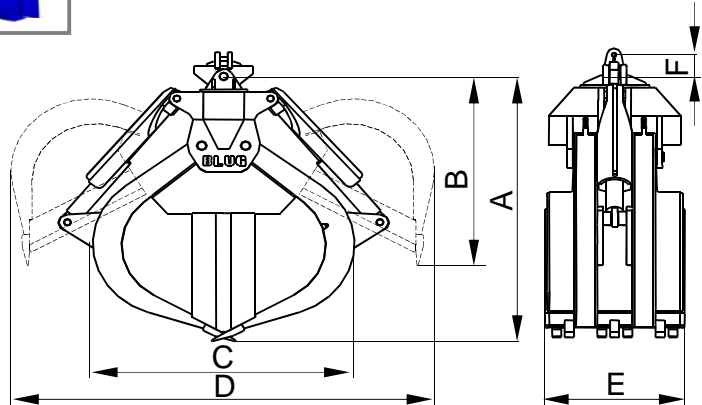

Reference	Capacity	Cylinder quantity	Working pressure	Crane SWL	Weight	Dimensions mm					
						A	B	C	D	E	F
CNAH-250-2,8	0,25	2	250	2,5	1040	2170	1600	1490	1960	420	Depending on forklift truck / mobile crane's suspension
CNAH-400-2,8	0,4	2	250	2,5	1100	2170	1600	1490	1960	610	
CNAH-550-2,8	0,55	2	250	3,2	1180	2170	1600	1490	1960	800	
CNAH-650-2,8	0,65	2	250	3,2	1250	2200	1620	1510	1980	1000	
CNAH-800-2,8	0,8	2	250	4	1320	2200	1620	1510	1980	2000	

SUBJET TO CHANGE WITHOUT NOTICE.

You can request any model's offer visiting our web site www.blug.es or sending an email to comercial@blug.es