

More information:

[www.blug.es/eng/productos/](http://www.blug.es/eng/productos/)

# BLUG®

Credeblug, s.l.

MACHINE TYPE

HOOK

WORKING SYSTEM

ELECTRO-HYDRAULIC

MATERIAL TO BE HANDLED

REFERENCE

**GG-103**

p. 47

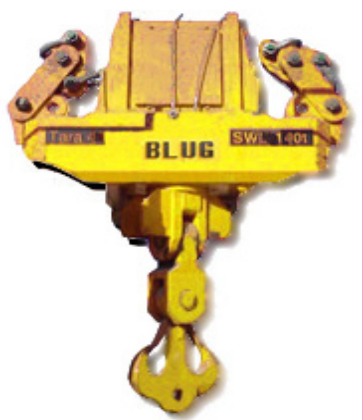

MATERIAL TO BE HANDLED

ALL KIND OF LOAD

TYPE

ROTATING

RELATED PRODUCTS



PEH-101



PEB-200



PED-201

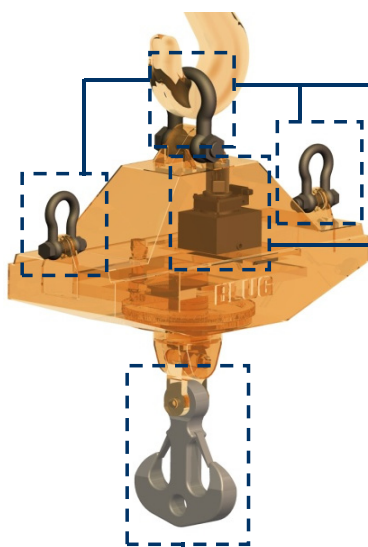

Simple / double lifting by high strength shackles

Rotation conditions adjustment and control by internal hydraulic unit

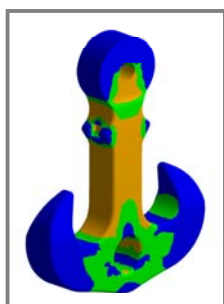

Structure validated by Finite Elements Analysis



Double hook according to standard DIN 15402

### Equipment needed

- Hook(s) or lifting chain(s).
- Electric connection for hydraulic unit.

### Technical information

- Robust structure in S355 J2G3 rolled steel.
- Full rotation (360°) for a perfect load's positioning.
- Design & fabrication according to standard FEM 1001/98 section I.
- CE conformity.

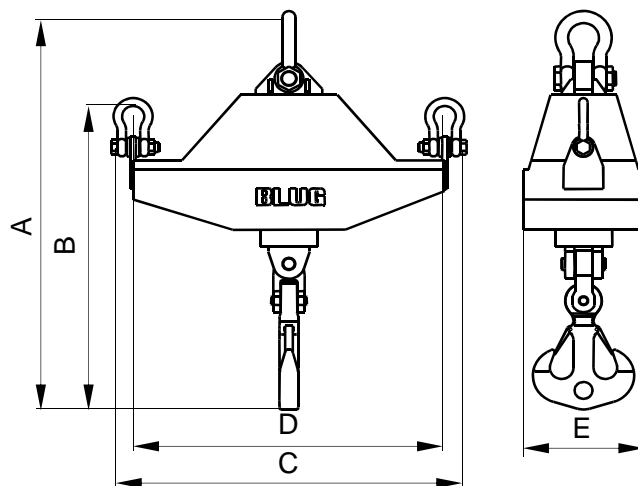

Reference	Capacity t	Engine kW	Intensity 400 V A	Working pressure bar	Rotation speed rpm	Crane SWL t	Weight kg	Dimensions mm				
								A	B	C	D	E
GG-103-10	10	0,75	2,1	175	3	12	550	1480	1130	1140	1010	540
GG-103-15	15	0,75	2,1	200	3	18	910	1780	1430	1570	1400	560
GG-103-20	20	1,5	3,7	200	3	22	1340	1860	1530	1840	1650	580
GG-103-25	25	1,5	3,7	200	3	28	1450	1960	1620	2000	1800	760
GG-103-32	32	2,2	5,5	220	3	35	1700	2600	2240	2230	2000	1050
GG-103-40	40	2,2	5,5	220	3	42	1890	2650	2280	2260	2000	1070

SUBJET TO CHANGE WITHOUT NOTICE.

You can request any model's offer visiting our web site [www.blug.es](http://www.blug.es) or sending an email to [comercial@blug.es](mailto:comercial@blug.es)