

More information:

[www.blug.es/eng/productos/](http://www.blug.es/eng/productos/)

# BLUG®

Credeblug, s.l.

MACHINE TYPE

ORANGE PEEL GRAB

WORKING SYSTEM

ELECTRO-HYDRAULIC

MATERIAL TO BE HANDLED



REFERENCE

**P-1,8**

p. 3

RELATED PRODUCTS



**PR8-1,8**



**P-3N**



**PM4-1,8**

MAX. MATERIAL DENSITY

**1,8 T/M<sup>3</sup>**

STRUCTURE

**ROUND**

MIXED SCRAP, BALED SCRAP WOOD, FRAG SCRAP, INDUSTRIAL REFUSE, MISCELLANEOUS SCRAP, SCRAP 1-2...

Hydraulic unit equipped with self-regulated piston variable flow pump

Complete load through maximum penetration force applied with special profile jaws designed for the product

Full protected hydraulic cylinders

Special penetration teeth built in wear resistant manganese steel

Equipment needed

- Hook(s) or lifting chain(s).
- Electric connection for hydraulic unit.

Technical information

- Robust structure in S355 J2G3 rolled steel.
- Oil tank tightly enclosed and protected from environment impurities.
- Reduced height, multi-stable, can work at any angle ( $\pm 60^\circ$ ).
- Design & fabrication according to standard FEM 1001/98 section I.
- CE conformity.

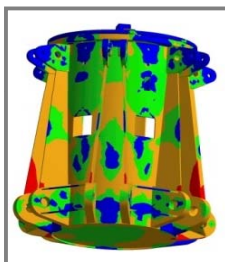

Structure validated by Finite Elements Analysis

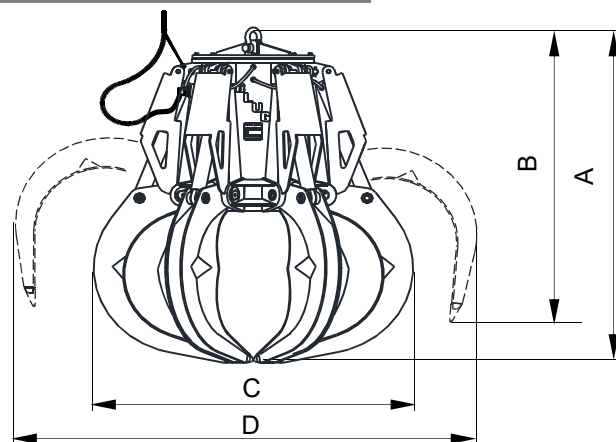

Reference	Capacity	Jaw quantity	Engine 40% ED	Intensity 400 V	Working pressure	Closing time (1)	Opening time	Crane SWL	Weight	Dimensions			
										m <sup>3</sup>	kW	A	bar
P5-500-1,8	0,5	5	7,3	14,5	140	10	7	2,5	875	1815	1530	1490	2285
P5-750-1,8	0,75	5	7,3	14,5	160	10	7	2,5	1000	1785	1510	1605	2215
P5-1000-1,8	1	5	10	20	165	8	5	4	1560	2100	1820	1850	2705
P5-1250-1,8	1,25	5	10	20	210	8	5	4	1650	2200	1850	1950	2900
P6-1600-1,8	1,6	6	14,5	28	130	9	5	6,3	2620	2410	2110	2260	3070
P6-2000-1,8	2	6	20,5	39	170	9	5	6,3	2710	2510	2145	2375	3270
P6-2500-1,8	2,5	6	20,5	39	210	10	6	8	2810	2660	2195	2475	3550
P6-3200-1,8	3,2	6	31,5	61	185	10,5	6	10	3940	2985	2480	2615	3895
P6-4000-1,8	4	6	31,5	61	200	12	7	12,5	4250	3135	2535	2805	4190
P6-5000-1,8	5	6	40	74,5	160	14,5	8	18	6600	3375	3020	3090	4480
P7-6300-1,8	6,3	7	51	94	190	17	9	20	7800	3575	3115	3245	4845
P7-8000-1,8	8	7	51	94	210	17	9	25	8000	3775	3205	3470	5220
P7-10000-1,8	10	7	70	129	210	15	8	30	9600	4160	3485	3805	5870
P7-12000-1,8	12	7	91	170	240	20	12	35	12200	4710	3960	4070	6090

SUBJET TO CHANGE WITHOUT NOTICE.

(1) THE LOAD APREHENSION TIME IS CONSIDERED AT 85% OF THE SHELLS STROKE.

You can request any model's offer visiting our web site [www.blug.es](http://www.blug.es) or sending an email to [comercial@blug.es](mailto:comercial@blug.es)