

More information:
www.blug.es/eng/productos/

BLUG[®]
 Credeblug, s.l.



REFERENCE
P-3N



MAX. MATERIAL DENSITY
3 T/M³

STRUCTURE
ROUND

RELATED PRODUCTS



PR8-3



P-3,5

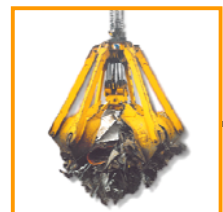

PM4-3

MACHINE TYPE
ORANGE PEEL GRAB
 WORKING SYSTEM
ELECTRO-HYDRAULIC
 MATERIAL TO BE HANDLED

CORE SCRAP, PIG-IRON, PELLETS, OA SCRAP, PELLETS, FERRO ALLOYS, INDUSTRIAL HEAVY WASTES, SMALL PACKAGES OF SCRAP...

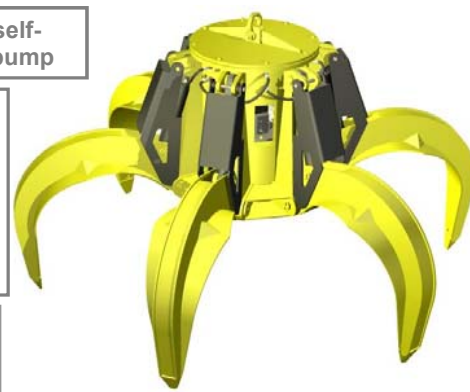
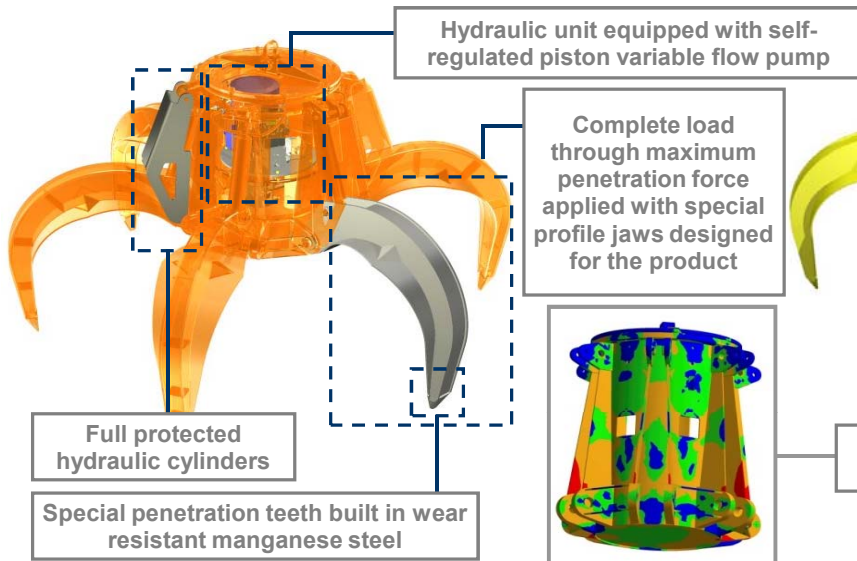

Structure validated by Finite Elements Analysis

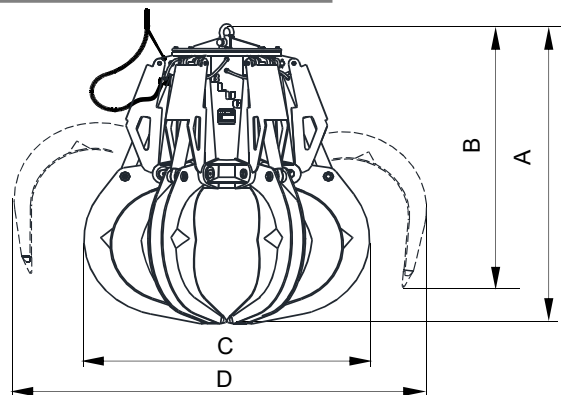
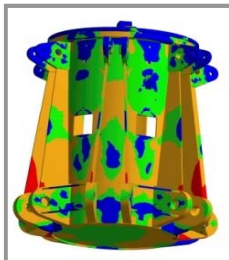

Equipment needed

- Hook(s) or lifting chain(s).
- Electric connection for hydraulic unit.

Technical information

- Robust structure in S355 J2G3 rolled steel.
- Oil tank tightly enclosed and protected from environment impurities.
- Reduced height, multi-stable, can work at any angle ($\pm 60^\circ$).
- Design & fabrication according to standard FEM 1001/98 section I.
- CE conformity.

Reference	Capacity	Jaw quantity	Engine 40% ED	Intensity 400 V	Working pressure	Closing time (1)	Opening time	Crane SWL	Weight	Dimensions mm			
	m ³		kW	A	bar	s	s	t	kg	A	B	C	D
P5-500-3N	0,5	5	10	20	125	8	5	3,2	1560	1890	1720	1540	2295
P5-750-3N	0,75	5	10	20	185	8	5	4	1650	1980	1780	1650	2455
P6-1000-3N	1	6	14,5	28	120	9	5	6,3	2800	2265	2050	1950	2745
P6-1250-3N	1,25	6	20,5	39	150	9	5	6,3	2950	2360	2090	2040	2930
P6-1500-3N	1,5	6	20,5	39	180	9	5	8	3100	2730	2400	2260	3400
P6-2000-3N	2	6	25,5	48,5	160	10,5	6	10	3900	2740	2410	2375	3450
P6-2500-3N	2,5	6	31,5	61	190	10,5	6	12,5	4100	2885	2450	2500	3710
P6-3200-3N	3,2	6	31,5	61	210	12	7	14	4400	2985	2480	2615	3895
P6-4000-3N	4	6	40	74,5	170	14	8	18	6600	3320	2980	2750	4360
P6-5000-3N	5	6	51	94	215	14	8	20	7200	3375	3020	3090	4480
P7-6300-3N	6,3	7	62,5	117	180	15	8	25	9100	3650	3300	3250	4800
P7-7000-3N	7	7	62,5	117	210	17	10	30	10300	3850	3450	3425	5000
P8-10000-3N	10	8	70	129	210	20	12	40	13000	4550	3900	3800	5800
P8-12000-3N	12	8	91	170	240	20	12	45	14000	4700	4050	3990	5990

SUBJET TO CHANGE WITHOUT NOTICE.

(1) THE LOAD APREHENSION TIME IS CONSIDERED AT 85% OF THE SHELLS STROKE.

You can request any model's offer visiting our web site www.blug.es or sending an email to comercial@blug.es