

More information:

[www.blug.es/eng/productos/](http://www.blug.es/eng/productos/)

**BLUG**<sup>®</sup>  
Credeblug, s.l.

REFERENCE

**PEA-1,1**



RELATED PRODUCTS



**P-0,7**



**C2A-2,8**



**C2AE-2,8**

MAX. MATERIAL DENSITY

**1,1 T/M<sup>3</sup>**

STRUCTURE

**ROUND**

MACHINE TYPE

**UNDERWATER GRAB**

WORKING SYSTEM

**ELECTRO-HYDRAULIC**

MATERIAL TO BE HANDLED

**WOODS, STONES, BRANCHES, TREES, MUDUS, FLOATING RESIDUES...**

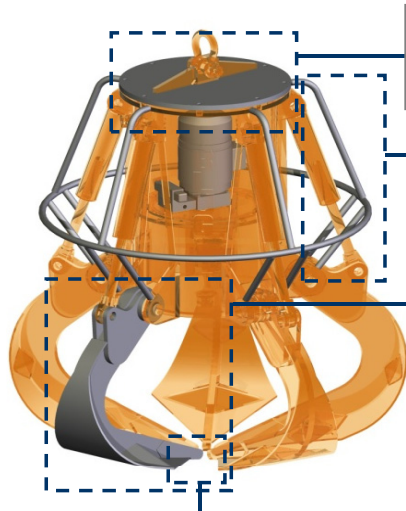

Reinforced top cover with sealing gasket to protect the engine and hydraulic unit

Full protected hydraulic cylinders

Complete load through maximum penetration force applied with special profile jaws designed for the product

Special penetration teeth built in wear resistant manganese steel

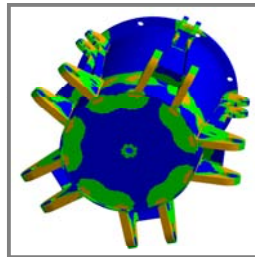

Structure validated by Finite Elements Analysis

**Equipment needed**

- Hook(s) or lifting chain(s).
- Electric connection for hydraulic unit.

**Technical information**

- Robust structure in S355 J2G3 rolled steel.
- Leak-proof pressurized oil deposit.
- Reduced height, multi-stable, can work at any angle ( $\pm 60^\circ$ ).
- Anticorrosive and anti-oxidant surface treatment with EPOXI-TAR.
- Design & fabrication according to standard FEM 1001/98 section I.
- CE conformity.

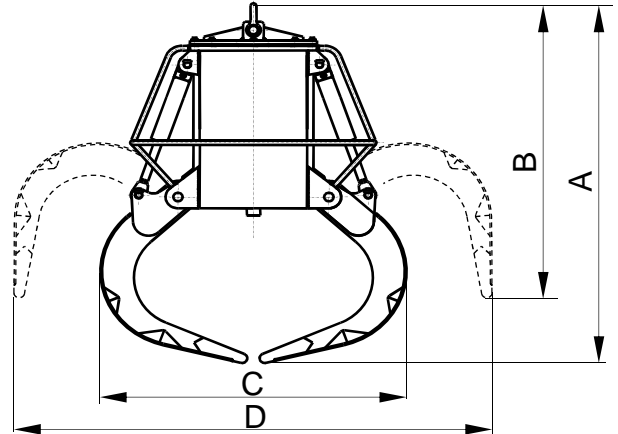

Reference	Capacity	Jaw quantity	Engine	Intensity 400 V	Working pressure	Closing time	Opening time	Crane SWL	Weight	Dimensions mm			
	m <sup>3</sup>									kW	A	B	C
PEA-150-1,1	0,15	4	3	6,7	100	4,5	2,2	1	420	1433	1347	940	1460
PEA-250-1,1	0,25	4	3	6,7	120	4,5	2,2	1	450	1520	1365	1050	1640
PEA-500-1,1	0,5	5	4	9,2	75	12	8	1,6	830	1615	1465	1290	1780
PEA-750-1,1	0,75	5	4	9,2	100	12	8	2,5	865	1690	1475	1445	1965
PEA-1000-1,1	1	5	5,5	11,5	140	12	8	2,5	960	1875	1525	1480	2290
PEA-1250-1,1	1,25	5	5,5	11,5	140	10	5	3,2	1500	2020	1770	1600	2505
PEA-1500-1,1	1,5	5	5,5	11,5	140	10	5	4	1580	2145	1855	1700	2630
PEA-2000-1,1	2	5	7,5	15	180	10	5	5	1685	2210	1835	1850	2890
PEA-2500-1,1	2,5	5	7,5	15	190	10	5	5	1800	2360	1925	2000	3075
PEA-3000-1,1	3	6	15	28,5	130	11	5,5	6,3	2630	2485	2140	2190	3130
PEA-4000-1,1	4	6	15	28,5	170	11	5,5	8	2850	2660	2200	2350	3465
PEA-5000-1,1	5	6	15	28,5	210	12	6	10	3000	2860	2240	2470	3850

SUBJET TO CHANGE WITHOUT NOTICE.

You can request any model's offer visiting our web site [www.blug.es](http://www.blug.es) or sending an email to [comercial@blug.es](mailto:comercial@blug.es)