

More information:

www.blug.es/eng/productos/

BLUG[®]
Credeblug, s.l.

MACHINE TYPE

TONG

WORKING SYSTEM

ELECTRO-MECHANICAL

OTHER POSSIBLE MATERIALS

REFERENCE

PED-201

p. 50

RELATED PRODUCTS



PMS-302



PEB-200



GG-103

MATERIAL TO BE HANDLED

ARCH-STONES

WORKING AXIS

HORIZONTAL

UP TO 4 ARCH-STONES HANDLING AT THE SAME TIME

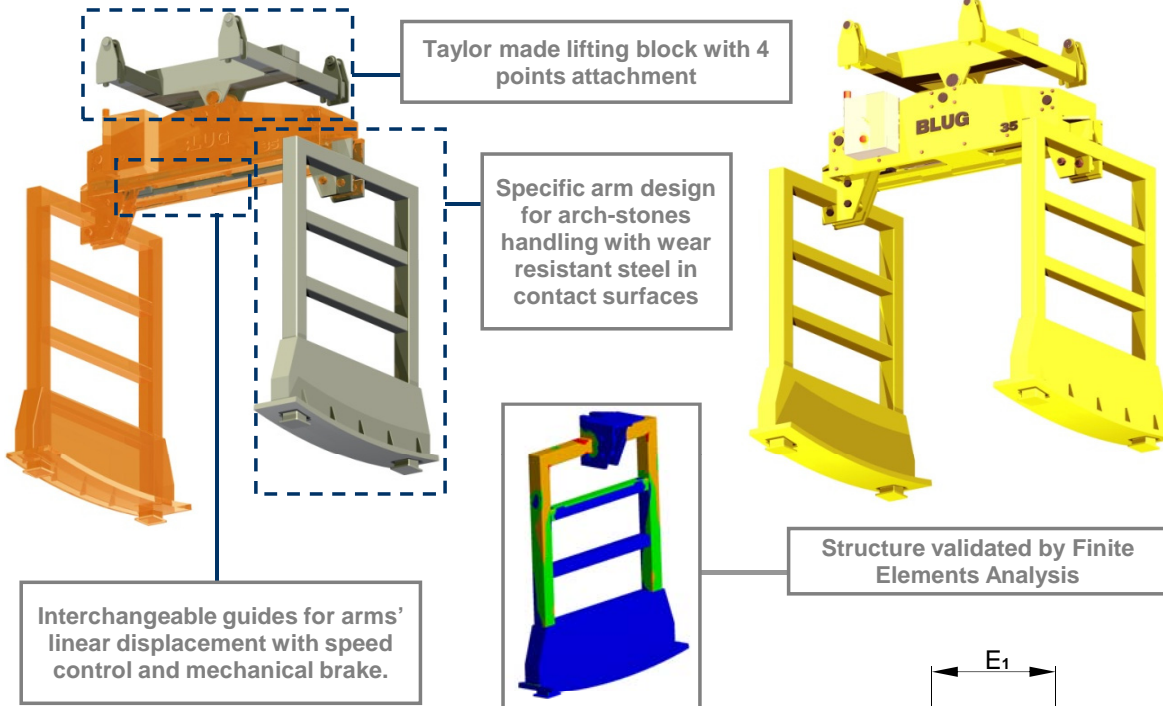

Equipment needed

- 4 lifting cables.
- Electric connection for electro-mechanical system.

Technical information

- Robust structure in S355 J2G3 rolled steel.
- Luminous signposting of status.
- Gripping force protection system.
- Maximum / minimum opening control device.
- Safety switch to avoid opening when loaded.
- Design & fabrication according to standard FEM 1001/98 section I.
- CE conformity.

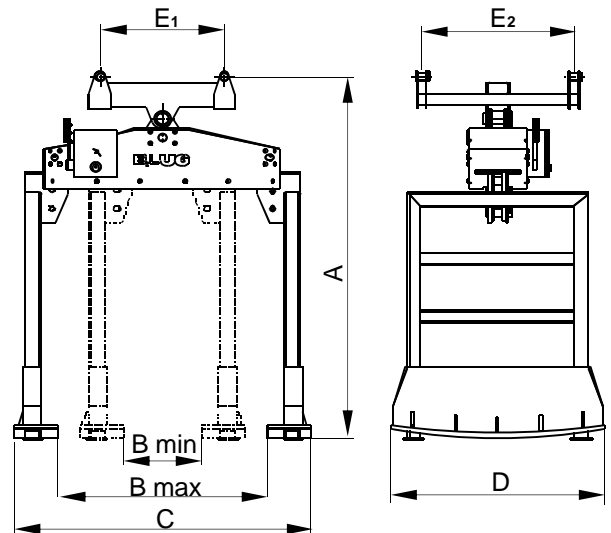

Reference	Capacity	Engine	Intensity 400 V	Arch-stones exterior radius	Crane SWL	Weight	Dimensions mm					
							t	kW	A	mm	t	kg
PED-201-10	10	1,5	3,4	2750	12,5	2500	2880	800	550	1400	2000	To define
PED-201-20	20	1,5	3,4	3725	25	3250	3050	1350	1000	1950	2000	
PED-201-30	30	2,2	5,15	5520	35	3900	3350	1850	1200	2550	2000	
PED-201-35	35	2,2	5,15	5770	40	4200	3650	1950	1150	2750	2000	

SUBJET TO CHANGE WITHOUT NOTICE.

You can request any model's offer visiting our web site www.blug.es or sending an email to comercial@blug.es