



RELATED PRODUCTS



PEH-100



PEH-102



PEH-104

MACHINE TYPE

TONG

WORKING SYSTEM

ELECTRO-HYDRAULIC

OTHER POSSIBLE MATERIALS

MATERIAL TO BE HANDLED

CYLINDRICAL PARTS

WORKING AXIS

HORIZONTAL

SINGLE TIMBER, GRAPHITE ELECTRODES AND ALL TYPE OF CYLINDRICAL PARTS HANDLING

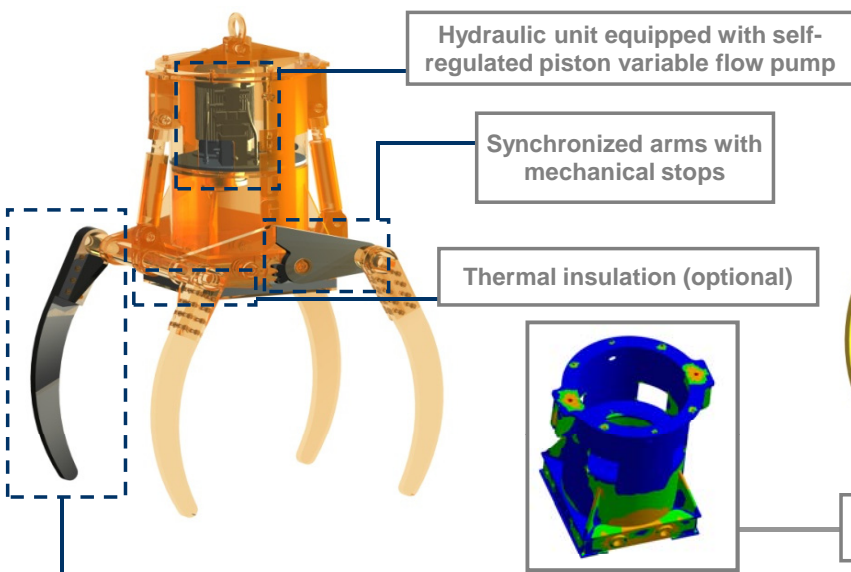

Structure validated by Finite Elements Analysis

Arm's design with optimal penetration that allows full loading in all the operations thanks to a kinematic design at lifting and penetration mode

Equipment needed

- Hook(s) or lifting chain(s).
- Electric connection for hydraulic unit.

Technical information

- Robust structure in S355 J2G3 rolled steel.
- Oil tank tightly enclosed and protected from environment impurities.
- Reduced height, multi-stable, can work at any angle ($\pm 60^\circ$).
- Design & fabrication according to standard FEM 1001/98 section I.
- CE conformity.

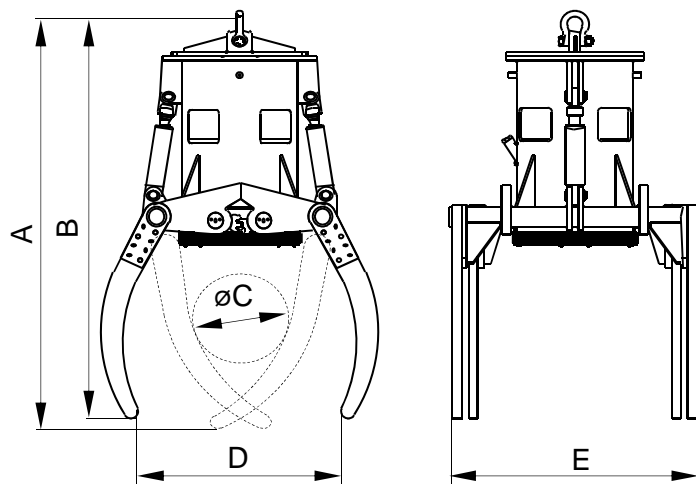

Reference	Capacity	Engine 40% ED	Intensity 400 V	Working pressure	Closing time	Opening time	Crane SWL	Weight	Dimensions				
	kg	kW	A	bar	s	s	t	kg	A	B	C	D	E
PEH-101-600	600	5,5	10,5	120	5	3	2	650	1530	1370	350	1000	1040
PEH-101-1000	1200	7,3	14,5	200	5	3	2	820	1550	1350	500	1100	1200
PEH-101-1600	1500	7,3	14,5	120	8	4	4	1930	2680	2590	600	1200	1400
PEH-101-2500	2500	10	20	160	8	4	5	2120	2790	2720	700	1260	1550
PEH-101-4000	4000	10	20	210	9	5	6,3	2300	2850	2560	800	1600	1700

SUBJECT TO CHANGE WITHOUT NOTICE.

You can request any model's offer visiting our web site www.blug.es or sending an email to comercial@blug.es