

More information:

www.blug.es/eng/productos/

BLUG[®]

Credeblug, s.l.

MACHINE TYPE

TONG

WORKING SYSTEM

ELECTRO-HYDRAULIC

OTHER POSSIBLE MATERIALS

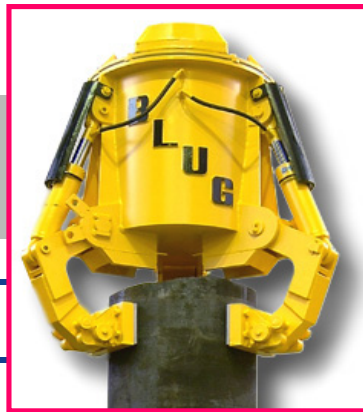

REFERENCE

PEH-104

p. 48

RELATED PRODUCTS



PEH-101



PEB-200

MATERIAL TO BE HANDLED

ELECTRODES

WORKING AXIS

VERTICAL

ALL TYPE OF GRAPHITE ELECTRODES AND CYLINDRICAL PARTS

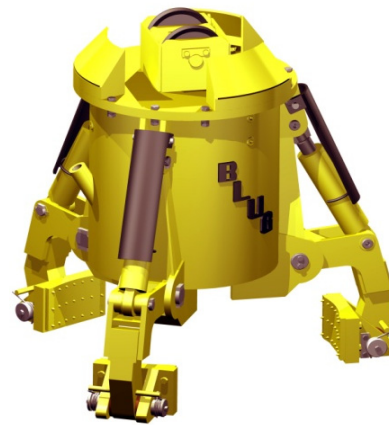
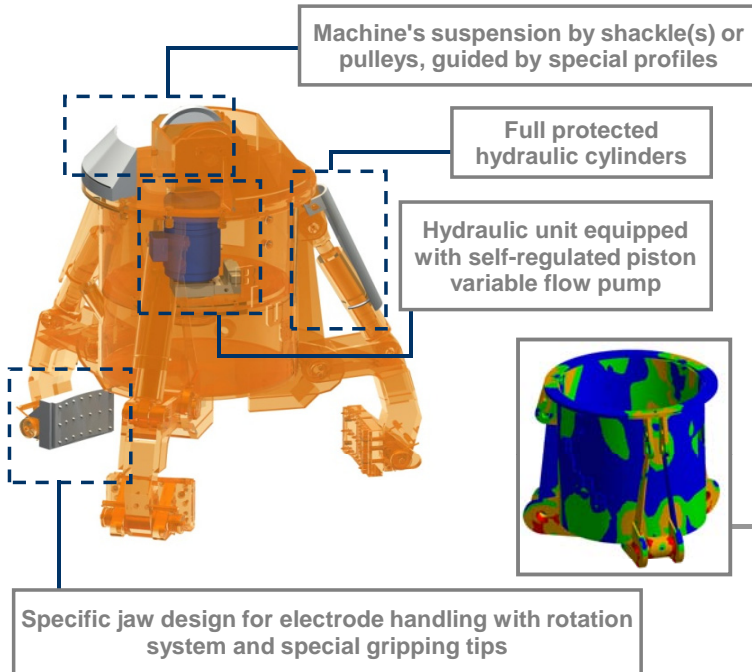

Structure validated by Finite Elements Analysis

Equipment needed

- Hook(s) or lifting chain(s).
- Electric connection for hydraulic unit.

Technical information

- Robust structure in S355 J2G3 rolled steel.
- Oil tank tightly enclosed and protected from environment impurities.
- Synchronized movement of 3 the arms.
- Design & fabrication according to standard FEM 1001/98 section I.
- CE conformity.

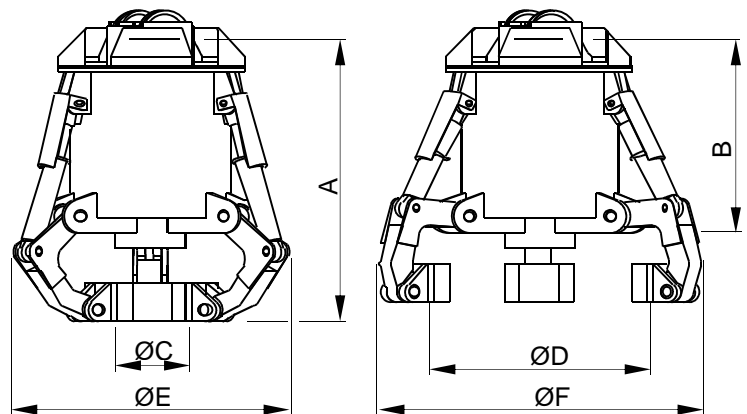

Reference	Capacity	Engine	Intensity 400 V	Working pressure	Closing time	Opening time	Crane SWL	Weight	Dimensions mm					
	t	kW	A	bar	s	s	t	kg	A	B	ØC	ØD	ØE	ØF
PEH-104-1	1	3	6,7	150	10	6	2,5	750	1080	820	150	700	1050	1240
PEH-104-2,5	2,5	5,5	10,5	120	7	4	4	950	1350	980	250	950	1200	1470
PEH-104-4	4	5,5	10,5	150	7	4	6	1100	1380	1020	360	1100	1290	1560
PEH-104-5	5	7,5	15	130	12	6	6,3	1300	1740	1310	450	1300	1550	1860
PEH-104-6	6	7,5	15	150	12	6	8	1460	1800	1330	550	1450	1680	1980

SUBJET TO CHANGE WITHOUT NOTICE.

You can request any model's offer visiting our web site www.blug.es or sending an email to comercial@blug.es