

More information:

www.blug.es/eng/productos/

BLUG[®]

Credeblug, s.l.

MACHINE TYPE

GRAPPLE

WORKING SYSTEM

MECHANICAL

OTHER POSSIBLE MATERIALS

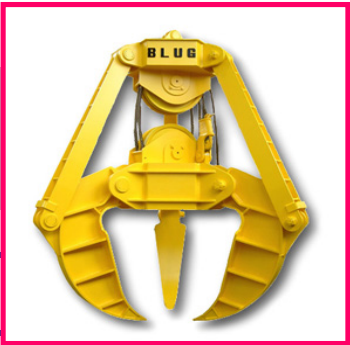

REFERENCE

PMB-300

p. 51

RELATED PRODUCTS



PM4-1,8

MATERIAL TO BE HANDLED

ROCKS

CABLE QUANTITY

2



PM4-3

IRREGULAR UNITARY STONES FOR BREAKWATER CONSTRUCTION

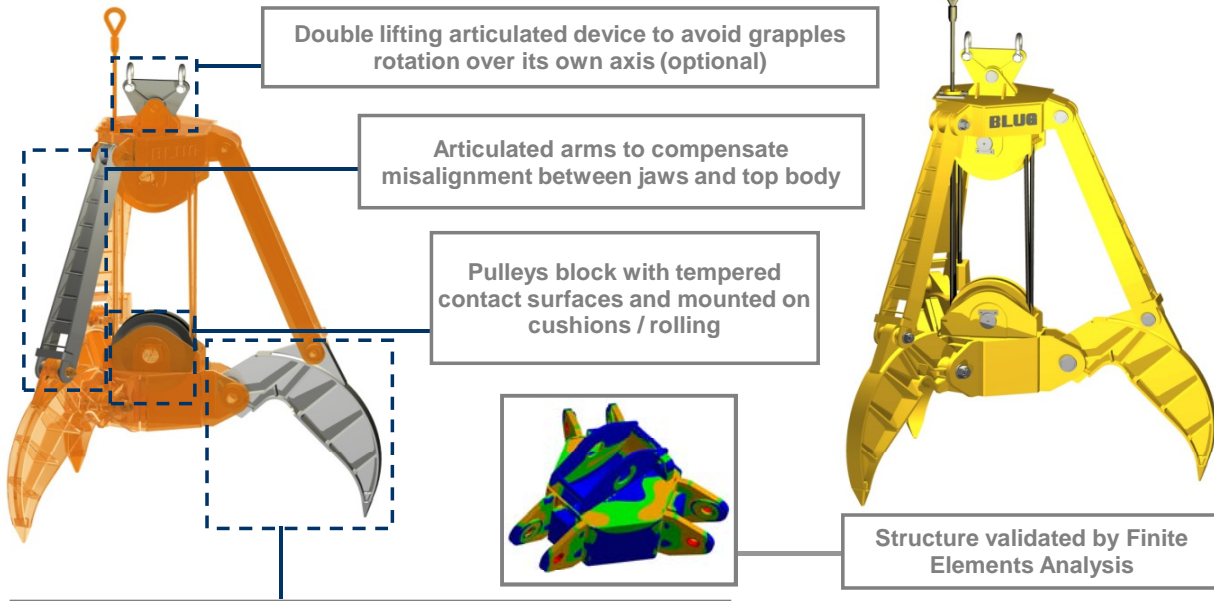

Complete load through maximum penetration force applied with special profile jaws designed for the product with special penetration teeth built in wear resistant manganese steel

Equipment needed

- 1 lifting cable.
- 1 opening / closing cable.

Technical information

- Robust structure in high strenght steel.
- Complete load through maximum penetration force.
- Ideal relation between capacity / dead weight.
- Design & fabrication according to standard FEM 1001/98 section I.
- CE conformity.

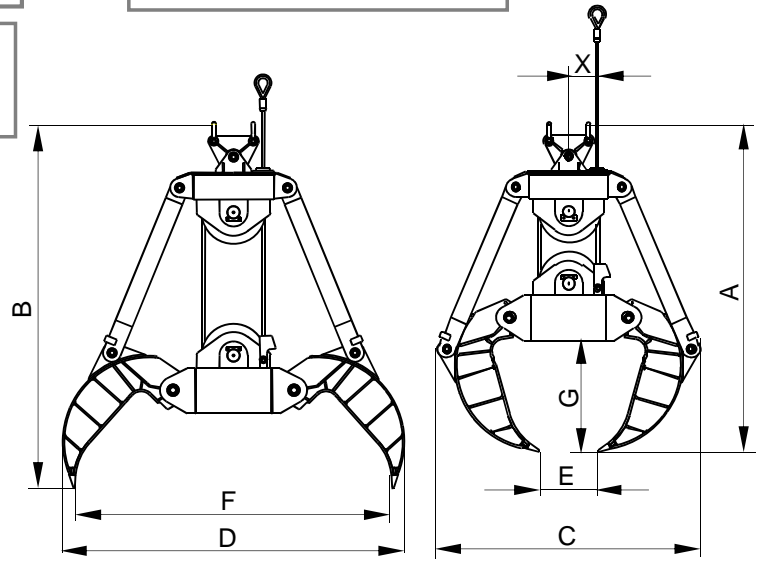

Reference	Capacity	Withdrawn cable	Pulley Ø	Cable Ø	Crane SWL	Weight	Dimensions							
							mm							
	t	m	mm	mm	t	kg	A	B	C	D	E	F	G	X
PMB-300-5	5	3,2	500	22	10	3100	3000	3300	2300	2940	400	2800	980	240
PMB-300-6	6	3,2	500	22	10	3300	3040	3360	2360	3020	420	2850	990	240
PMB-300-8	8	3,2	500	22	12	3700	3080	3420	2430	3080	450	2900	1010	240
PMB-300-10	10	3,9	630	32	16	5400	3690	4080	2860	3670	500	3400	1200	290
PMB-300-15	15	4,6	710	40	22	6600	3970	4390	3430	4350	750	4060	1420	380

SUBJET TO CHANGE WITHOUT NOTICE.

You can request any model's offer visiting our web site www.blug.es or sending an email to comercial@blug.es