

More information:

www.blug.es/eng/productos/

BLUG[®]

Credeblug, s.l.

REFERENCE

PMS-302

p. 53



RELATED PRODUCTS



GG-103



GC-301

MACHINE TYPE

TONG

WORKING SYSTEM

MECHANICAL

MATERIAL TO BE HANDLED

MATERIAL TO BE HANDLED

SLABS

TYPE

AUTOMATIC

ANY TYPE OF SLABS AND UNIFORM HEAVY PARTS HANDLING

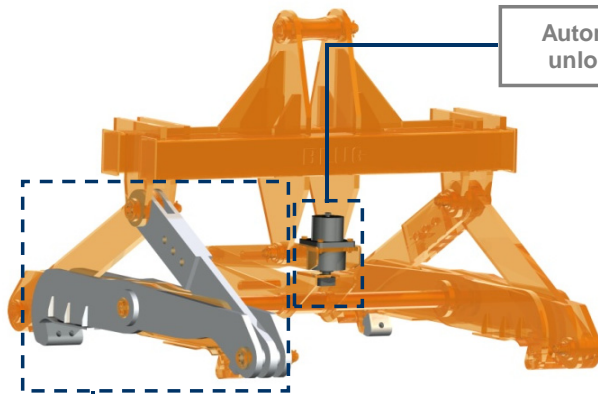

Automatic locking-unlocking system

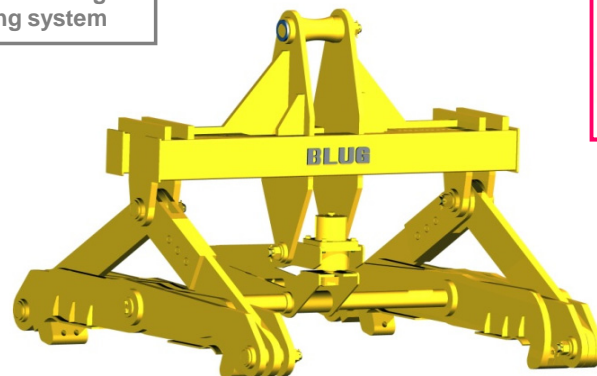

Specific arm design for slabs handling manufactured in high strength steel (700 Mpa) with wear resistant steel in contact surfaces

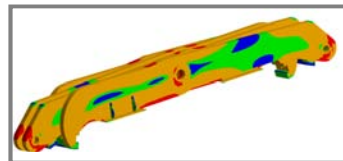

Structure validated by Finite Elements Analysis

Equipment needed

- Lifting hooks or cables.

Technical information

- Robust structure in high strength steel.
- Assured load through maximum penetration force.
- Ideal relation between capacity / dead weight.
- Design & fabrication according to standard FEM 1001/98 section I.
- CE conformity.

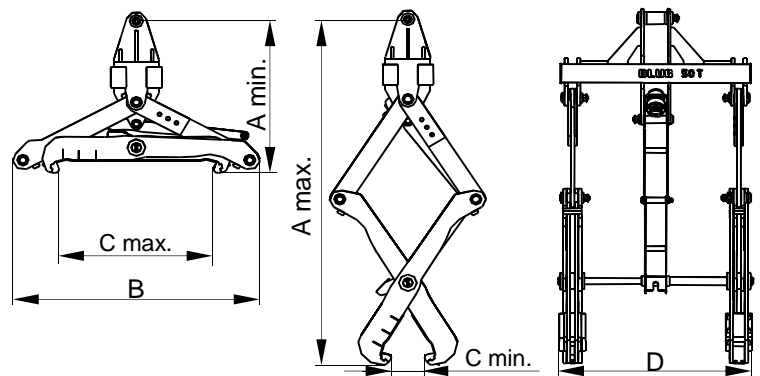

Reference	Capacity	Slab's maximum width	Slab's minimum width	Load's maximum temperature	Crane SWL	Weight	Dimensions					
							mm					
	t	mm	mm	°C	t	kg	Amax	Amin	B	Cmax	Cmin	D
PMS-302-5	5	1500	600	800	8	1400	3800	2250	2100	1600	500	1100
PMS-302-10	10	1650	600	800	12	1900	4000	2150	2350	1800	500	1400
PMS-302-20	20	1800	600	800	25	4200	4100	2000	2500	1900	500	1700
PMS-302-30	30	1950	600	800	38	6500	4200	1800	2700	2000	500	2000
PMS-302-40	40	2100	600	800	48	7400	4300	1650	2900	2100	500	2400
PMS-302-50	50	2200	600	800	60	8200	4400	1500	3100	2300	500	2800

SUBJET TO CHANGE WITHOUT NOTICE.

You can request any model's offer visiting our web site www.blug.es or sending an email to comercial@blug.es